

Owner's Manual

Residential Factory Built Fireplace

Operation • Maintenance • Installation

DELTA FUSION

Keep these instructions for future use.



Industrial Chimney Company Inc.
400 J.-F. Kennedy, St-Jerome, QC, Canada, J7Y 4B7
Telephone: (450) 565-6336
www.icc-rsf.com

RSF-IIDF_2016-07

Dear Customer,

The DELTA FUSION incorporates technology with elegance to give you a beautiful view of the fire without compromising on heating efficiency or environmental quality.

We have designed your new DELTA FUSION to be easy to install, operate and maintain. It is in your best interest to become familiar with it. Study your manual to be sure that the installation is correct, and then follow the guidelines for operation and maintenance.

We at RSF Woodburning Fireplaces congratulate you on your choice of the DELTA FUSION, and are confident that you have purchased a fireplace that is *simply, the best.*

Sincerely,

RSF Woodburning Fireplaces TEAM

July 2016

TABLE OF CONTENTS

SAFETY FIRST	3	SIDE DECORATIVE FACINGS REMOVAL AND ADJUSTMENT	11
Do's AND DONT's	3	INSTALLATION	12
CREOSOTE: FORMATION AND REMOVAL	3	MOVING THE DELTA FUSION	12
GENERAL SPECIFICATIONS	4	LOCATION	12
THE COMBUSTION CONTROL SYSTEM	4	CEILING CLEARANCE	12
OPTIONS	4	SECURING THE FIREPLACE IN PLACE	12
UNIT DIMENSIONS AND CLEARANCES	5	FRAMING GUIDES INSTALLATION	15
OPERATION	7	FRAMING	15
AIR CONTROL	7	OUTSIDE AIR DUCT	16
IMPROVING EFFICIENCY	7	CHIMNEY	16
IMPORTANCE OF DRAFT	7	CHIMNEY INSTALLATION	17
BURN TIME VS HEAT OUTPUT	7	OFFSET CHIMNEY	19
FUEL	7	CHASE ENCLOSURE	19
FIRST FIRES	8	MASONRY CHIMNEY	20
LIGHTING	8	FINISHING AROUND THE FIREPLACE	21
ADJUSTING THE BURN RATE	8	HEARTH EXTENSION	21
REFUELING	8	BENEATH HEARTH EXTENSION	21
TROUBLESHOOTING PROBLEMS	9	MANTEL	22
MAINTENANCE	9	REFRACTORY BRICK INSTALLATION	22
CHIMNEY CLEANING	9	LISTING LABEL	23
DISPOSAL OF ASHES	9	COMPLETE OPTIONS LIST	24
GENERAL CLEANING	10	REPLACEMENT PARTS	25
GLASS CLEANING	10	LIMITED WARRANTY	26
PAINT	10		
DOOR ADJUSTMENT	10		
TOP AND BOTTOM LOUVERS REMOVAL AND ADJUSTMENT	10		

SAFETY FIRST

DO'S AND DONT'S

If this fireplace is not properly installed, a house fire could result. For your safety, follow the installation directions. Contact your local authority having jurisdiction (such as municipal building department, fire department, fire prevention bureau, etc.) regarding restrictions and installation requirements, and the need to obtain a permit.

To ANYONE using this fireplace: these **DO's** and **DO NOTs** are for your safety.

1. **DO** read this instruction manual before lighting your first fire.
2. **DO** burn seasoned wood fuel or a combination of densified fuel logs and wood fuel.
3. **DO operate the fireplace with the door fully closed.** If the door is left partly open, gas and flame can be drawn out of the fireplace opening, creating both fire and smoke hazards.
4. **DO** keep all combustible materials (furniture, firewood, etc.) at least 4' away from the front of the fireplace.
5. This fireplace needs periodic inspection and repair for proper operation. **DO** learn to properly use it and maintain it.
6. **DO** have at least one smoke detector on each level of the house and at least one carbon monoxide detector.
7. **DO** read the section about MOVING THE DELTA FUSION before you begin the installation.
8. To avoid glass breakage, **DO NOT** slam the fireplace door.
9. **DO NOT** ever use gasoline, gasoline-type lantern fuel, kerosene, charcoal lighter fluid or similar liquids to start or freshen up a fire in this fireplace. Keep all such liquids well away from the fireplace while it is in use.
10. **DO NOT overfire the fireplace. If you are unable to slow down the burn rate of the fire or if the chimney connector behind the top louver glows red, you are overfiring the fireplace.**
11. **DO NOT** use a fireplace grate or other products not specified for use with this fireplace.
12. The burn rate is set by the automatic air control at the factory. **DO NOT** tamper with the air control. **DO NOT** install a flue damper that would allow you to reduce the chimney draft and thus slow the minimum burn rate.
13. To avoid damaging the fireplace, **DO NOT** operate it in a manner inconsistent with the operating instructions in this manual.



◆ **NOTE:** We strongly recommend that our products be installed and serviced by professionals who are certified by the National Fireplace Institute in the U.S. or by Wood Energy Technology Transfer Inc. in Canada.



CREOSOTE: FORMATION AND REMOVAL

When wood is burned slowly, it produces tar and other organic vapors which combine with the expelled moisture from the wood to form creosote. The creosote vapors can condense in the relatively cool chimney of a slow burning fire. When ignited, this creosote makes an extremely hot fire. The chimney should be inspected periodically during the heating season to see if a creosote build-up has occurred. If a significant layer of creosote has accumulated (1/4" or more), it should be removed to reduce the risk of chimney fire.

❖ **WARNING: BURN DRY WOOD ONLY. DO NOT BURN: DRIFTWOOD, TREATED WOOD, COAL, GARBAGE, OR PLASTIC.**

Do not use construction scraps (e.g. 2x4 or plywood scraps) as your only supply of fuel as you can overheat and seriously damage the fireplace. Do not use more than one wax fuel log (e.g. Duraflame) at a time. Use only firelogs that have been evaluated for fireplace use. In Canada, they should meet the requirements of ULC/ORD-C127-M1990. Refer to the firelog warnings and caution markings prior to use.

GENERAL SPECIFICATIONS

The DELTA FUSION fireplace offers more than 500 sq. inches of pure fire viewing which defines it as a "Fireplace" under the United States Environmental Protection Agency (EPA) 2015 regulations.

It is also environmentally friendly, and meets the 2020 United States Environmental Protection Agency (EPA) particulate emission standard with crib wood at an emission rate of 1.3 grams per hour.

The DELTA FUSION has an efficiency of 60%. This has been established using the higher heating value of the wood, using data from a crib wood EPA emission test and using CSA B415.1-10 calculations.

It has been shown to deliver heat ranging from 40 000 to 95 000 BTU/h with an average of 70 000BTU/h. Please refer to the "Improving efficiency", the "Importance of draft", the "Burn Time vs Heat Output" and the "Fuel" sections to better understand the various factors that influence the efficiency and heat output of your fireplace.

THE COMBUSTION CONTROL SYSTEM

Since the door is sealed, air for combustion comes through the DELTA FUSION's air control. The draft control is an assembly that increases or reduces the amount of air permitted into the firebox. A bi-metallic coil in the air control allows more air when the unit is cold, and less air when the unit is hot, guarding against overheating. The air control is fully automatic; there is no user access to the air control.

Control the fire as you would any normal fireplace, using one or two logs at a time for a smaller fire, or more logs for more heat. Remember: when the fireplace is hot, the automatic air control will reduce the combustion air inlet since the bi-metallic coil will shut the air control damper part way.

OPTIONS

Rock Retainer Kit

To simplify the installation of thin non-combustible materials such as ceramic tile or sliced brick, we have designed a rock retainer kit (FO-KD3). It is not designed or required for full brick or stone. The rock retainer kit is composed of metal lath and a metal finishing edge to provide texture to the facing of the fireplace, improving the hold of mortar.

Internal Blower

For increased air circulation and marginally more heat output, you can add the Circulating Internal Blower (FO-FDHB5-N) to your DELTA FUSION.

Gravity Vent

Gravity vents distribute hot air through ducts connected to the top of the fireplace and do not require a blower. If you have any rooms directly above or adjacent to the room with the fireplace that you would like to heat, you may want to consider the Gravity Vent Kit (FO-V2). You can install one or two gravity vent kits. If you chose to install only one, we recommend installing it on the left side. If you prefer a different look for your gravity vent(s) you can change the grill(s) for a contemporary vent grill (FO-VGC).

Central Heat Blower

To maximize the distribution of the heat generated by your DELTA FUSION fireplace throughout many rooms and different floors, consider the Central Heat Option. With our Central Heat Blower (FO-FDHB6-1), you can connect to existing central heating ducts or run dedicated ducts to circulate the fireplace heat to one or many rooms. The Central Heat Control (FO-FDHC6) will automatically control the Central Heat Blower via a wall thermostat and thermal switch. The Zone Heat Control (FO-FDHCZ1) along with Zone Damper Kits (FO-FDHCZ2) will provide the same features as the Central Heat Control but for more than one heating zone.

◆ **NOTE:** Many options require wiring and/or electricity for their installation. If there is any chance that any of these options will be installed in the future then suitable wiring should be run during framing. Otherwise, it will be difficult to install these options later.

Detailed installation instructions are included in the box with each option. These can also be obtained from our Internet Web Site: www.icc-rsf.com.

UNIT DIMENSIONS AND CLEARANCES

For the side wall clearance

Distance from the fireplace side standoff to the side of the firebox opening:
13 1/2"

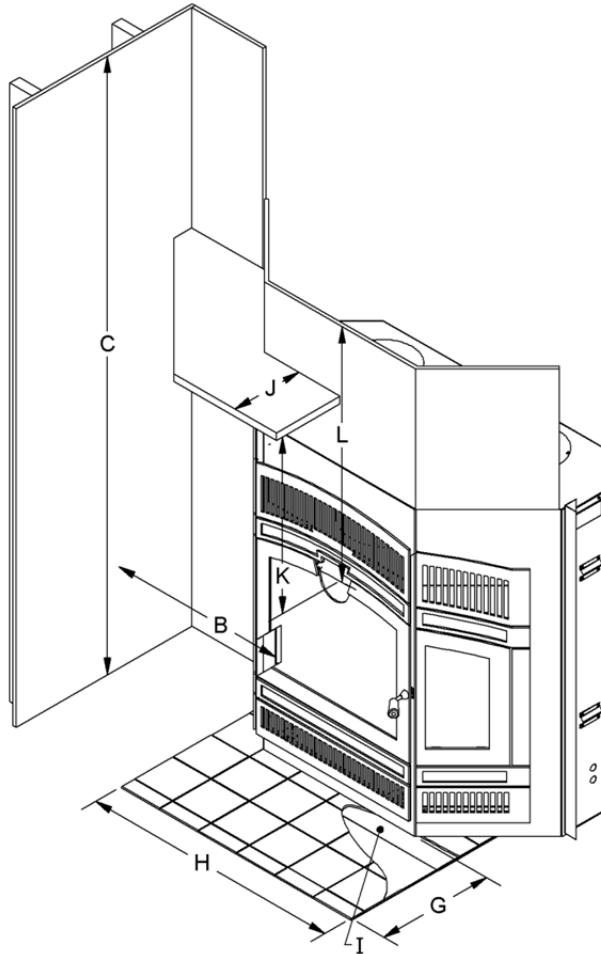

For the mantel shelf clearance

Distance from the fireplace base to the top of the firebox opening:
28 3/4"

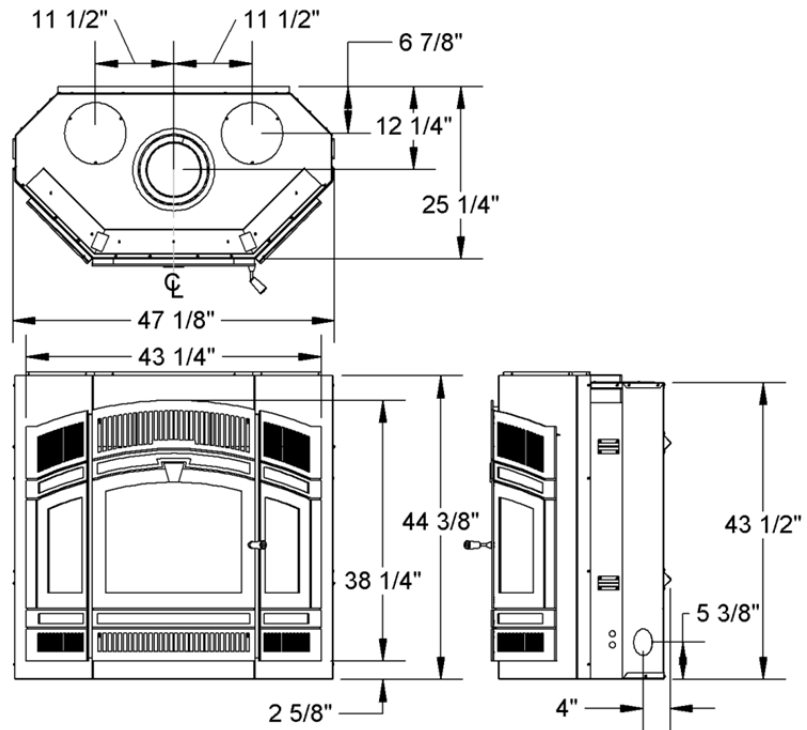

Figure 1 Unit Dimensions and Clearances

Table 1 Unit Dimensions and Clearances

A	Distance of combustible material from side and back standoffs, and the base of the fireplace	0" (0,0 mm)
B	Minimum distance of side wall to the side of the firebox opening.	24 ½" (622 mm)
C	Ceiling clearance: from the base of the fireplace to the ceiling above the fireplace. Applies inside and outside the fireplace enclosure.	7' (2,13 m)
D	Minimum chimney height: minimum total chimney height from fireplace top to below the chimney rain cap (chimney height increases with offsets and altitude, refer to "Chimney" section for details).	12' (3,66 m)
E	Maximum chimney height: maximum total chimney height from fireplace top to below the chimney rain cap.	40' (12,19 m)
F	Maximum chimney height supported by the fireplace.	16' (4,88 m)
G	Minimum depth of non-combustible hearth extension: from the front of the fireplace.	18" (457 mm)
H	Minimum width of non-combustible hearth extension: total width, must be centered on firebox opening.	36" (914 mm)
I	Minimum width of the spark guard.	23 ¾" (603 mm)
J	Maximum mantel shelf depth.	12" (305 mm)
K	Minimum height of a combustible mantel above the top of the door opening: from the highest point of the top of the door opening to below the combustible mantel (refer to the "INSTALLATION: Mantel" section for particulars).	24" (610 mm)
L	Minimum distance of combustible materials above the fireplace facing from the firebox opening (other than the combustible mantel shelf, see J and K above): includes framing and wall surface.	38 ½" (978 mm)

OPERATION

AIR CONTROL

The bi-metallic coil is a unique feature built into your DELTA FUSION fireplace. It serves as a fully automatic combustion air control.

As the fireplace heats up, it will activate the bi-metallic coil. This will automatically begin to shut down the air entering the firebox, slowing the combustion process. This will save you wood, reduce emissions, improve efficiency, and prevent the fireplace from overheating and causing potential damage to the firebox.

IMPROVING EFFICIENCY

The location of your fireplace will affect how efficiently it heats the home. Your fireplace should be located in part of the house you want to be the warmest. Trying to heat the main floor with a fireplace in the basement will generally overheat the basement and waste fuel. Certain RSF options offer the ability to move heat from the main floor to the basement. This allows you to efficiently heat your primary space while also heating the basement as a secondary space.

The efficiency will also be influenced by the draft in the chimney which will be influenced by various factors (refer to "Importance of draft" below) and by the amount of wood burning at any point (see "Burn Time vs Heat Output" below). The efficiency will also be influenced by the quality of the wood (refer to "Fuel" below).

All of these factors must be taken into account and optimized so you can recover the maximum heat from your DELTA FUSION.

IMPORTANCE OF DRAFT

Draft is the natural force which pulls air from the fireplace up the chimney. The strength of draft in your chimney depends on a variety of factors, including chimney height, nearby obstructions, altitude, etc.

Excessive draft can result in a hotter fire than intended or reduced burn times as more air is pulled through the fireplace. It will also result in less heat recovery since the heat will not have as much time to radiate into the room before being sucked into the chimney.

Weak draft can result in smoke entering the room and difficulty lighting or operating the fireplace. Weak draft is often incorrectly associated as a blockage in the air intake for the fireplace. Adding chimney height is the most common solution. See Table 2 for minimum chimney height recommendations.

BURN TIME VS HEAT OUTPUT

The faster your fireplace burns the more heat it will create; however, faster fires result in much more hot air flow up the chimney which means you are sacrificing efficiency. Fast burning fires (lots of air) go through much more wood than slow burning fires. The DELTA FUSION burns at a fixed rate depending on the heat inside the firebox. It will burn quickly during light up and then gradually slow down to offer the best efficiency and emissions reduction.

FUEL

All modern high efficiency fireplaces and woodstoves are designed to burn best with seasoned cordwood. Seasoned wood can be defined as wood that has been cut, split and let dry under cover for a minimum of 6 months, preferably a year or more. Dry seasoned wood generally contains less than 20% moisture content. Attempting to burn fuel with a high moisture content will be difficult and result in lower efficiency, increased creosote buildup and dark deposits on the glass. It is possible to burn a very large amount of wood, and get very little heat if the wood is wet.

The type of wood you select is also important. All types of wood give off more or less the same number of BTU's per pound. Since softer woods are less dense than hardwoods it is possible to put more weight of hardwood in the firebox; in other words all woodburning appliances will burn longer and more evenly with hardwoods. Never burn scrap, garbage, treated wood or driftwood as they produce much more pollution and can corrode the firebox and chimney as well. Burning large amounts of paper, cardboard, mill ends or construction waste can easily over fire and damage the fireplace or even ignite a chimney fire if the flue is dirty.

FIRST FIRES

You will experience a very slow start-up during the first few fires and it may be difficult to close the door at first. The refractory bricks contain moisture from manufacturing and require a few hot fires to evaporate the moisture. While moisture remains in the bricks, there will be black with smoke deposits on them. When the moisture has dissipated, the bricks will turn white. Unlike cast iron stoves, there is no need to cure the fireplace itself by starting with small fires and progressively larger ones. Feel free to light a large fire from the very start.

You will experience an odor during the first few fires. This odor comes from curing paint and oil burning off the metal. The odor may be strong enough to set off your smoke detector. Open the doors and windows to allow the room to properly ventilate.

LIGHTING

Start by laying your fire starter and kindling. Traditional fire starter is crumpled newspaper; make sure to use enough to light the kindling (5-6 pieces should do). Next lay 3 or 4 layers of kindling crisscrossed over the newspaper. Using plenty of kindling ensures that the chimney will heat up quickly and establish a strong draft, **never use any flammable liquids**. Light the paper and close the door most of the way, but don't shut it completely, keep it about 1" from being completely closed. If the door is positioned correctly you will see air rushing into the fireplace, this will help the lighting process.

Once the kindling is lit and sustaining fire, you can add some small pieces of seasoned cordwood. Use the andirons in front to help position the cordwood so as not to flatten and smother the fire you've just created. Always add at least 3 pieces of cordwood. Position your cordwood in a manner that the fire will hit several pieces as it rises and has air gaps to flow through. Continue to leave the door slightly open until the cordwood is lit, about 3-5 minutes. Close the door completely when the fire is established.

During light up, it is normal for the glass to accumulate some soot and become dark. As the fireplace heats up, this should burn off and reveal a nice view of the fire.

❖ **WARNING: DO NOT USE A GRATE OR ELEVATE THE FIRE.**

ADJUSTING THE BURN RATE

The DELTA FUSION is designed to optimize efficiency at all times. Since there are no user controls to adjust the burn rate, the easiest method is to learn how many logs you need at a time for the amount of heat you require. In addition to the amount of wood and the size of the logs, take the time to experiment with split and unsplit logs (split logs will burn faster than unsplit logs) as well as placing the logs parallel or perpendicular to the door (perpendicular will burn faster than parallel). You will soon discover that having no user control for the burn rate is not a limitation.

REFUELING

Have your next wood load ready when you open the door. The temperature in the firebox will decrease as the door is open, so decreasing the amount of time the door is open will allow the firebox to remain hot. Do not rush.

Turn off the central heat and/or internal blowers, if installed. The blowers may cause smoke to spill out of the fireplace if they are running.

The door should be opened slowly to keep smoke from spilling into your room. If you have a problem with smoke spillage, check to see that all kitchen and bathroom fans have been shut off. They can cause negative pressure in the house which pulls smoke out of the fireplace.

Take the time to poke and stir the unburnt wood that is left in the firebox. This will help revive the fire. Place the new logs in the firebox. Try to maintain a clear path in front of the pilot, which is the metal tube centered between the two andiron posts. The pilot brings an influx of air close to the coals that will help to keep the fire going. Once the new wood has been loaded, keep the door slightly ajar for about 3-10 minutes to get the fire going depending on how well seasoned is your cordwood and how much coals were left in the firebox. Once the new wood is well lit, close the door.

TROUBLESHOOTING PROBLEMS

If smoke comes into the house when the door is opened:

- You may have opened the door too quickly and created a suction of air into the room, this can be avoided by opening the door more slowly.
- Ensure your chimney is clean and your chimney cap is not plugged. Chimney caps with screens are more likely to become clogged with creosote buildup.
- Make sure you have adequate chimney height for your system. Refer to the "Chimney" section of this manual and make sure to take altitude, and number of elbows into consideration.
- If you have purchased the central heat kit option or the circulating internal blower, make sure the blower is off before opening the door.
- Check to see if other fans in the home are running, particularly a kitchen range hood, or bathroom exhaust fan. This can affect the pressure in the home.
- Try opening a window near the fireplace a little, this will equalize the pressure in the home and should correct a draft problem. Once proper draft is established the window can be closed.
- Make sure you've used enough kindling to establish a hot fire quickly. The most likely time that smoke will enter the home is during the lighting process.

If your fireplace burns excessively fast, seemingly uncontrollably:

- Check all door seals and gaskets to ensure that air is not leaking into the firebox. See "Door Adjustment" for details of how to verify the tightness of the door.
- Inspect the secondary air tubes in the top of the fireplace to ensure they are in good condition. An unwanted hole in the secondary air tubes can bring additional unwanted air into the fireplace.

MAINTENANCE

CHIMNEY CLEANING

Check the chimney for creosote buildup every week or so until experience shows how often you need to clean it. A buildup of ¼" or more should be cleaned before more creosote accumulates. Close the fireplace door(s) prior to sweeping. Use an 8" round brush.

The baffle in the firebox can be pulled forward or completely removed to gain better access to the flue from below. Whether you decide to remove it or pull it forward, great care should be given not to damage the back secondary air tube with the sweeping brush or while moving, removing and/or reinstalling the baffle.

To pull the baffle forward, simply pull it over the front secondary air tube.

To remove the baffle, first remove the front secondary air tube. Simply unscrew the secondary air tube on the left side, slide the tube toward the right until the left end drops out of its hole. Slide the tube back towards the left to get the right end out of its hole. To remove the baffle, push up and slide it off the brackets.

Do not forget to replace both the baffle and the secondary air tube if you removed them and be sure to have the holes on the secondary air tube facing toward the front and the screw back in place.

DISPOSAL OF ASHES

Remove the ashes before they become too deep, before you have a spillage problem when you open the door.

The ashes should be placed in a metal container with a tight-fitting lid. The closed container of ashes should be placed on a non-combustible floor or on the ground, well away from all combustible materials pending final disposal. If the ashes are disposed of by burial, or otherwise locally dispersed, they should be retained in the closed container until all cinders have thoroughly cooled.

GENERAL CLEANING

The high heat paint can be cleaned with a soft damp cloth. Use a mild detergent and water. Do not use abrasive cleaners.

GLASS CLEANING

In a controlled combustion firebox, temperatures are not always high enough to keep the glass perfectly clean. A good hot fire once a day usually cleans off most of the deposits that have accumulated. Remember: the drier the wood, the cleaner the glass. A word of caution: although heat will not break the glass, impact can. Be careful not to hit the glass.

❖ **WARNING: NEVER CLEAN THE GLASS WITH AN ABRASIVE CLEANER. USE ONLY A CLEANER RECOMMENDED BY YOUR DEALER. NEVER CLEAN THE GLASS WHILE IT IS HOT, A SERIOUS BURN CAN RESULT. THERE ARE A NUMBER OF EXCELLENT WOOD STOVE GLASS CLEANERS AVAILABLE WHICH ARE FAR SUPERIOR TO REGULAR GLASS AND OVEN CLEANERS FOR WOOD STOVE APPLICATIONS.**

PAINT

❖ **WARNING: AVOID SPRAYING CERAMIC GLASS CLEANER OR OTHER CLEANERS ON THE PAINT OF THE FIREPLACE. THEY MAY REMOVE THE PAINT AND MAKE TOUCHUPS DIFFICULT.**

You can touch up the face of the DELTA FUSION with *Stove Bright* Metallic Black high temperature paint which is available at most fireplaces dealers. Follow the directions outlined on the spray can. **DO NOT** attempt to paint the fireplace while it is still warm. Keep the spray can away from any source of heat or open flame. Ensure that there is adequate ventilation in the room from the time you start painting until the paint is dry. *Stove Bright* is available in a wide range of colors if you want to change the color of your DELTA FUSION.

We recommend that you take the time to protect or remove any item that you do not want to paint such as: the door glass, the plated door, the fireplace surroundings, etc. The glass can be removed from the door but you will have to replace the gasket.

DOOR ADJUSTMENT

To check for a proper door seal, insert a thin sheet of paper between the door and the front of the fireplace and latch the door. Pull gently but firmly on the sheet of paper. If there is resistance on the paper, the adjustment is correct. Repeat this procedure along all sides of the door.

The most important factor for controlling the burning rate of the DELTA FUSION is a good seal on the door gasket. If the door gasket is worn or damaged to the point where the seal is not adequate as described above, then remove and replace the gasket. Replacement kits are available from your RSF dealer.

To ensure a proper seal on the latch side, you can adjust the tightness of the door against the front of the fireplace as follows:

1. Open the door and turn the handle 360° counterclockwise. Beware not to over tighten the door latch; this will result in premature failure of the door gasket or cause undue stress on the door handle.
2. Verify the seal with the sheet of paper as described above.

If needed, the hinges can be adjusted to improve the alignment of the door latch with respect to the hole in the fireplace facing, and for easy installation/removal of the door.

◆ **NOTE:** An improperly adjusted door seal can have a significant effect on the performance and durability of the fireplace. A poorly adjusted door can result in reduced efficiency, over firing, excessive wood consumption and premature fireplace failure.

TOP AND BOTTOM LOUVERS REMOVAL AND ADJUSTMENT

The top and bottom louvers are held in place by two screws located at the top right and left corners of each louver (see Figure 2). They also have hooks at the bottom of each louver so that when you remove the screws they will not fall down.

The hole through which the screws hold each louver in place is oblong, allowing for some left to right adjustment to better align with the door frame.

SIDE DECORATIVE FACINGS REMOVAL AND ADJUSTMENT

Each side decorative facing is held in place by four bolts: two at the top and two at the bottom (see Figure 2). They are not visible from the front of the fireplace. They are only accessible from behind the side decorative facings. To gain access to the four bolts, the top and bottom louvers need to be removed.

To adjust the position of a side decorative facing, just loosen all four nuts, one on each bolt. Make sure to tighten all four nuts once the side decorative facing is in its proper position.

To remove the side decorative facing, just remove the four nuts and pull the entire panel forward. Be careful the panel is quite heavy and could crush toes or damage wood flooring is dropped.

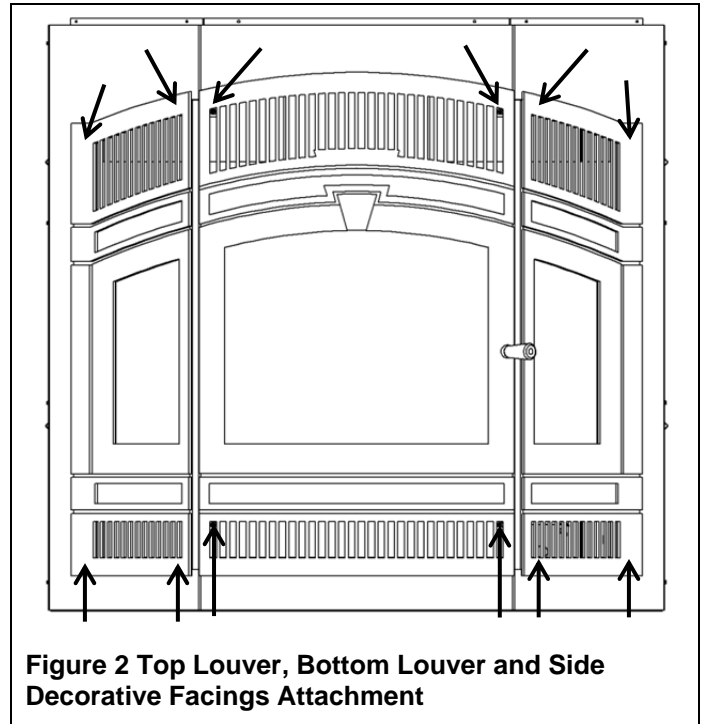

Figure 2 Top Louver, Bottom Louver and Side Decorative Facings Attachment

INSTALLATION

Check with your local authority having jurisdiction (such as municipal building department, fire department, fire prevention bureau, etc.) regarding restrictions and installation requirements, and the need to obtain a permit.

Remove the fireplace door. Store it in a safe place until the installation and finishing work is finished. Side windows must be adequately protected.

MOVING THE DELTA FUSION

The fireplace weighs about 650 lb (295 kg) as shipped. It is possible to reduce the moving weight of 40 lb (18 kg) by moving the fireplace without its crate, of another 130 lb (60 kg) by removing the refractory bricks and of an additional 25 lb (12 kg) by removing the baffle.

We recommend using a furniture dolly to move the fireplace. Simply remove the top and bottom louvers as well as the door to be able to attach the fireplace to the dolly with a strap around the fireplace. Do not elevate the fireplace and dolly beyond a 45° angle to move.

♦ **NOTE:** If using an Eskelera a 2 x 4 will have to be placed between the two forks before using.

LOCATION

Your DELTA FUSION fireplace may be installed in many different ways (see Figure 3) without any special floor reinforcement. We recommend that you take the time to plan your entire installation (fireplace, chimney, and options) before beginning the actual installation (refer to Figure 4).

Dimensions of the fireplace along with clearances are shown in Figure 1 and Table 1.

❖ **WARNING: IF THIS FIREPLACE IS NOT PROPERLY INSTALLED, A HOUSE FIRE CAN RESULT. FOR YOUR SAFETY, FOLLOW THE INSTALLATION INSTRUCTIONS AND CLEARANCES. DO NOT PACK REQUIRED AIR SPACES WITH INSULATION OR OTHER MATERIALS.**

1. Note the location of roof and floor joists. Try to choose a location that does not require cutting them.
2. If at all possible, run the chimney up through the inside of the house. If it must be run outside, it should be enclosed in an insulated enclosure (see Installation: Chase Enclosure). Remember, a cold chimney causes poor draft.

CEILING CLEARANCE

Ceiling clearance is the distance from the base of the fireplace to the ceiling.

Under no circumstances should the distance between the ceiling firestop and the base fireplace be less than the dimension specified in Table 1 (C).

SECURING THE FIREPLACE IN PLACE

The fireplace **MUST** be attached to the floor.

Using the four small brackets that were securing the fireplace to the crate, attach the casing or base of the fireplace to the floor. Position the brackets all around the fireplace in the same fashion as they were on the crate. If possible, try to have at least one of the brackets screwed into the floor joist with 2" wood screws.

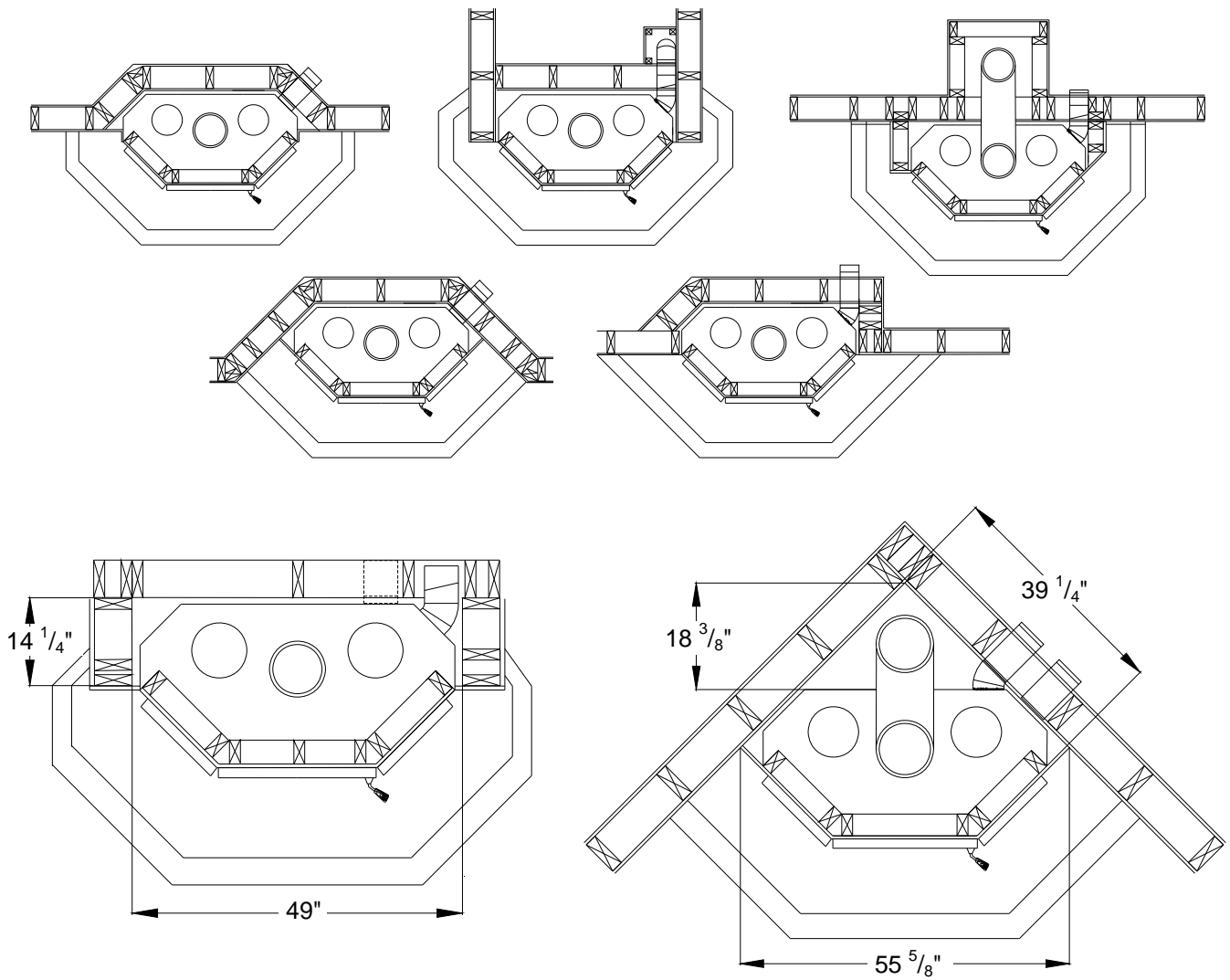

The framing dimensions are larger than required for ease of installation.

Use the provided framing guide to frame at 90° against the side of the fireplace. Use the optional 45° framing guide (FO-FDS45) if you want to finish the wall as a continuity of the angled facing. See "Framing Guides installation" section for more information regarding both framing guides.

Figure 3 Framing Examples

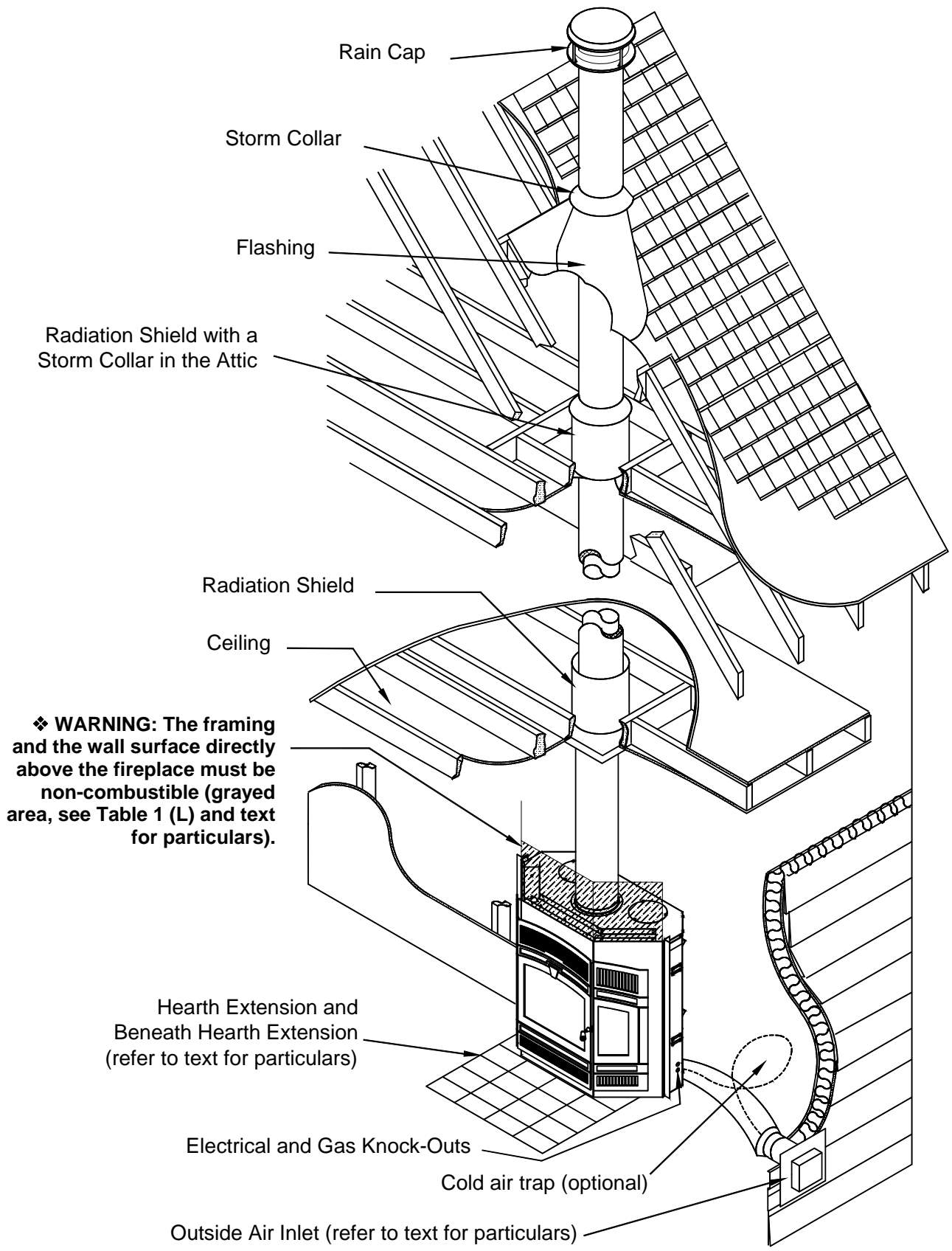

Figure 4 General Installation

FRAMING GUIDES INSTALLATION

Provided with the fireplace are two 90° framing guides that need to be installed one on each side of the fireplace facing. Simply remove the four (4) screws on the side of the facing and use them to attach the framing guide as shown in (see Figure 5).

The optional 45° framing guide (FO-FDS45) is installed in the same manner as the 90° framing guide. Just make sure to line up the 45° framing guide with the fireplace to ensure facing will be flush.

The framing goes behind the framing guide while the drywall goes in front.

FRAMING

The wall above the fireplace needs to be framed in steel studs to at least the height defined in Table 1 (L). With the fireplace, we provide a channel for the steel studs that is installed on top of the fireplace; the steel studs necessary to frame above the fireplace up to 97" from the base of the fireplace and the channel necessary to attach the steel studs to the ceiling (see Figure 6).

The provided steel studs can be cut shorter or be replaced with longer ones if necessary.

The channels have pre-drill holes that correspond to the center width of each steel studs. The two angled sides are framed ready to accept the gravity vent grill adapter if you decide to install the gravity vent option.

The rest of the enclosure walls (side(s) and back) can be framed with any suitable materials (2x4 or 2x6 studs, plywood, gypsum board, etc.).

Make sure to respect all combustible materials clearances specified in Table 1.

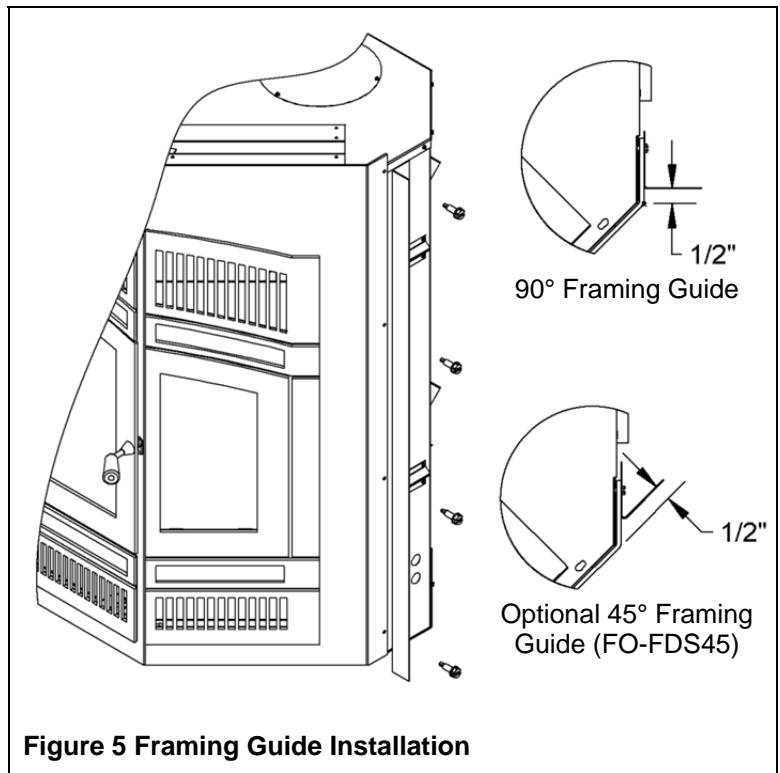

Figure 5 Framing Guide Installation

The framing goes behind the framing guide while the drywall goes in front.

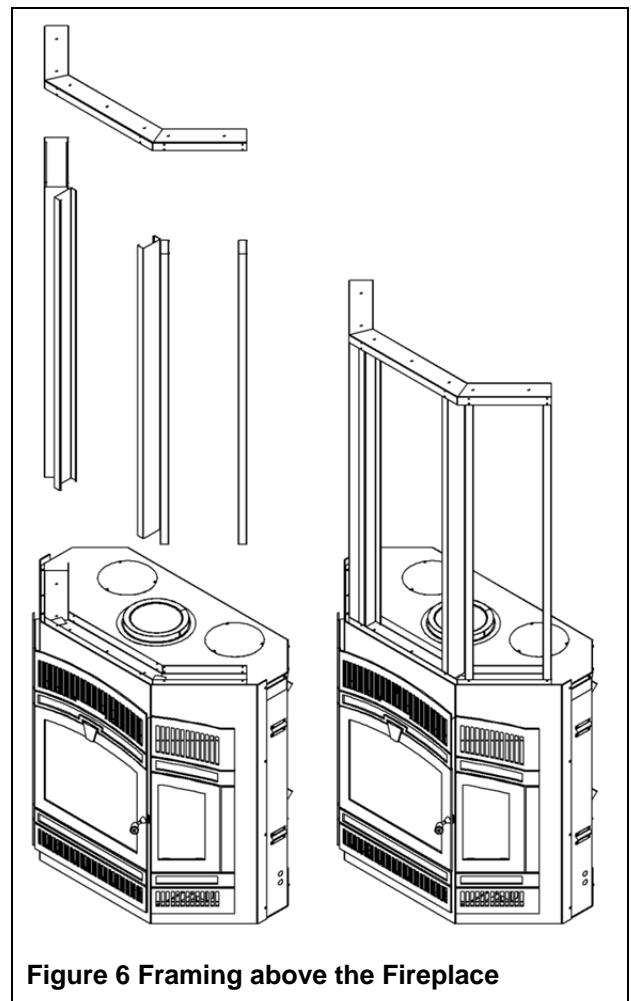

Figure 6 Framing above the Fireplace

OUTSIDE AIR DUCT

If an outside air duct is required in your jurisdiction, connect the outside air inlet to the outside after the fireplace is correctly positioned (see Figure 7).

Use an insulated aluminum flexible duct. The duct should not exceed 12' vertical rise above the base of the unit.

The air inlet should be at least 5' lower than the top of the chimney flue and must never terminate in attic spaces.

A 4" diameter duct can be used if the total duct run is less than 25'. For longer runs, use 5" diameter duct. Both 4" and 5" connecting sleeves are provided with the fireplace.

1. Find a convenient location for the combustion air duct and outside air inlet. The outside air inlet can be above or below floor level.
2. Make a 4 ¼" (5 ¼" if using a 5" diameter duct) hole in the outside wall of the house. Push the outside air inlet in from the outside. Seal the joint between the air inlet and the outside wall with an appropriate sealant.
3. Place the insulated flexible duct over the round sleeve on the outside air inlet. At both ends, carefully pull back the insulation and plastic cover, exposing the flexible duct. Then at each end, attach the duct with metal screws to the inlet and tube. Carefully push the insulation and cover back over the duct. Tape the plastic cover in place with 2" aluminum duct tape.

❖ CAUTION: WHEN RUNNING THE DUCT AROUND CORNERS, BE SURE TO PREVENT CRIMPING THE DUCT THAT WOULD RESTRICT THE COMBUSTION AIRFLOW.

CHIMNEY

This fireplace is certified for use with 8" ICC Model EXCEL chimney only. Please refer to Table 1 (D-E) for the minimum and maximum chimney height permitted with the DELTA FUSION fireplace.

We recommend that the minimum height be increased by approximately 6" for every 1000' elevation above sea level. Every 15°, 30° or 45° offset (one pair of elbows) also increases the minimum height. See Table 2 for more precise recommended flue heights.

For example, if you are living 6015' above sea level, your chimney should terminate at least 15' from the top of the fireplace if it is a straight chimney or at least 18'6" if one 30° offset is used as shown in Table 2.

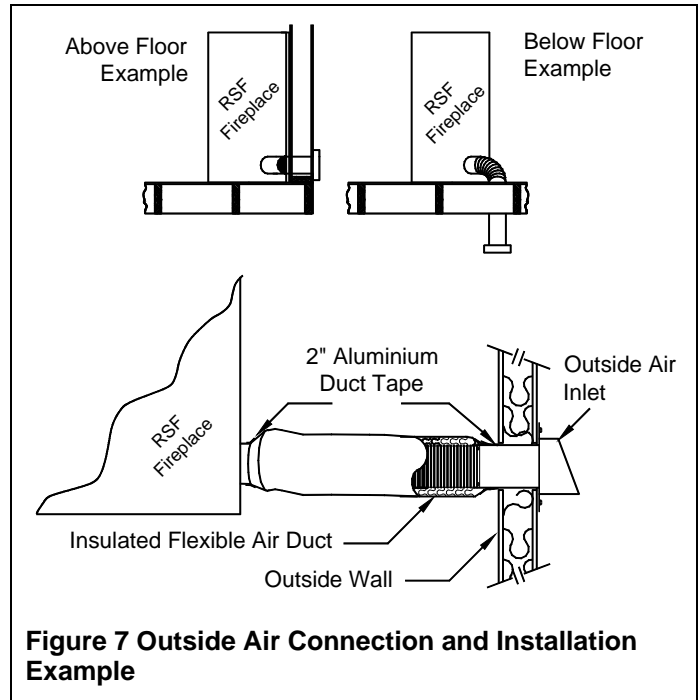

Table 2 Minimum Recommended Flue Heights

Elevation (ft)	Number Of Offset						
	Straight Chimney	1 x 15°	2 x 15°	1 x 30°	2 x 30°	1 x 45°	2 x 45°
0 - 1000	Minimum 12'	13'	14'	15'	18'	16'	20'
1001 - 2000	12'6"	13'6"	14'6"	15'6"	19'	16'6"	20'
2001 - 3000	13'	14'	15'	16'	19'6"	17'	21'6"
3001 - 4000	13'6"	14'6"	15'6"	17'	20'	18'	22'6"
4001 - 5000	14'	15'	16'	17'6"	21'	18'6"	23'
5001 - 6000	14'6"	15'6"	17'	18'	21'6"	19'	24'
6001 - 7000	15'	16'	17'6"	18'6"	22'	20'	24'6"
7001 - 8000	15'6"	16'6"	18'	19'	23'	20'6"	25'6"
8001 - 9000	16'	17'	18'6"	20'	24'	21'	26'6"
9001 - 10000	16'6"	17'6"	19'	20'6"	24'6"	22'	27'

Flue height is measured from the top of the fireplace to the top of the chimney before installing the rain cap.

If you have two different offsets (two pairs of different elbows), simply use the column for two offsets of the biggest pair of elbows at your elevation to get your Minimum Flue Height.

CHIMNEY INSTALLATION

Make sure to read the EXCEL Chimney installation manual concerning requirements for supports, bracing, anchors, etc. The EXCEL installation manual is available from your dealer or from our web site: "www.icc-rsf.com". Refer to Table 1 (F) for the maximum chimney height that can be supported by the top of the fireplace.

❖ **WARNING: THE CLEARANCE BETWEEN THE CHIMNEY AND COMBUSTIBLE MATERIAL MUST BE 2" OR MORE. DO NOT FILL THIS AREA WITH INSULATION.**

1. Cut and frame the required holes in the floor(s), ceiling(s) and roof where the chimney will pass through. The rough opening in the framing is 14" square (the opening can be slightly bigger, up to 14 1/2", but NEVER smaller).
2. From below, install a radiation shield in each floor through which the chimney passes. At the attic level, install a radiation shield and a storm collar as shown in Figure 8.

❖ **WARNING: A RADIATION SHIELD MUST BE INSTALLED AT EACH FLOOR WHERE THE CHIMNEY PASSES THROUGH.**

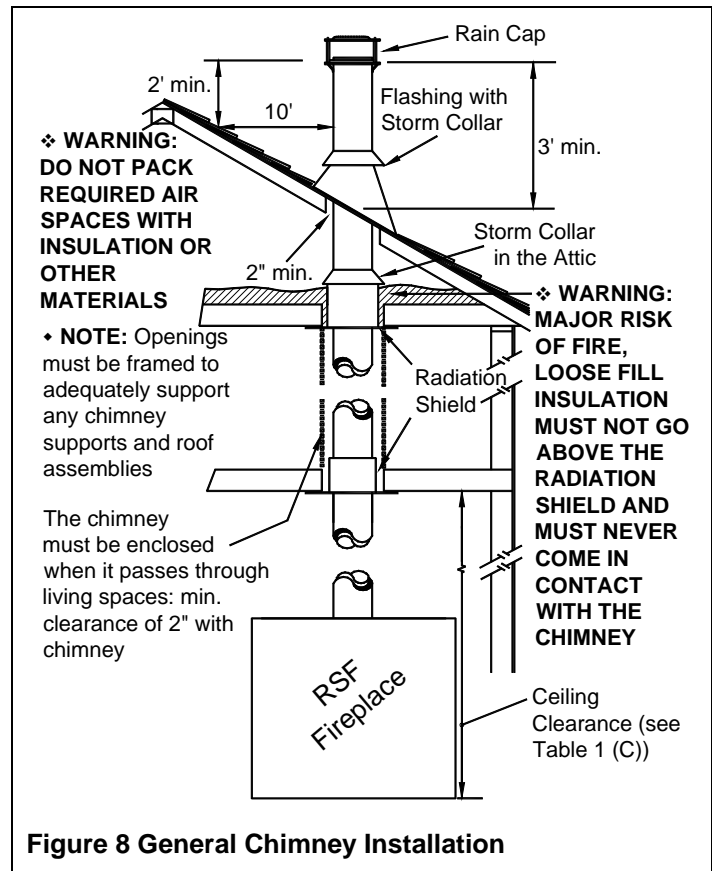

Figure 8 General Chimney Installation

3. Place the first chimney length on the fireplace. Secure the chimney length to the fireplace with the three screws provided.
- The chimney must extend at least 3' above its point of contact with the roof and at least 2' higher than any wall, roof, or building within 10' of it. If the chimney is higher than 5' above the roof, it must be secured using a roof brace.
4. At the roof, install a roof radiation shield. The roof radiation shield must be installed so it extends 1" above the roof line.
 5. Put the roof flashing into place.
 - If the chimney is enclosed to the roof: use a vented flashing
 - If the chimney is not enclosed to the roof: use a regular flashing.
 6. Seal the joint between the roof and the flashing with roofing tar. For sloping roofs, place the flashing under the upper shingles and on top of the lower shingles. Nail the flashing to the roof using roofing nails.
 7. Place the storm collar over the chimney and flashing. Seal it around the chimney with silicone sealer (**DO NOT use roofing tar**).
 8. Fit the rain cap on the chimney. Secure it tightly in place.

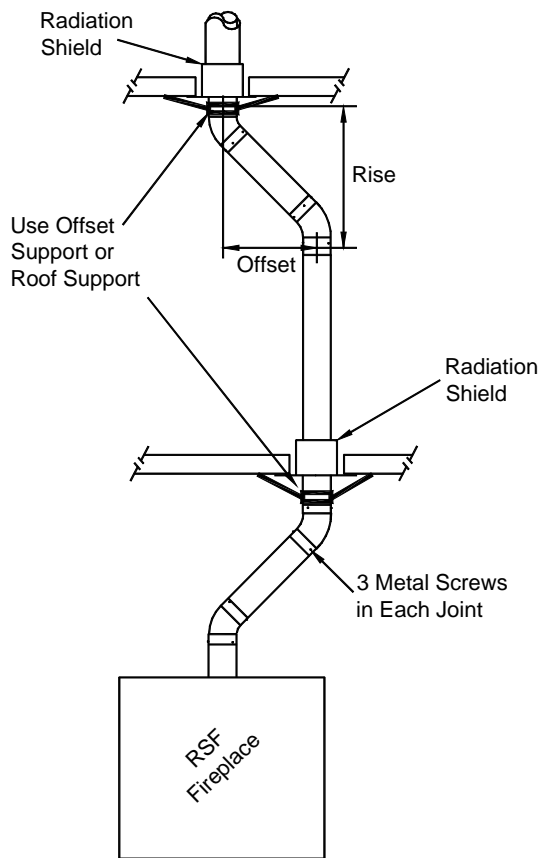

Figure 9 Offset Chimney Installation Example

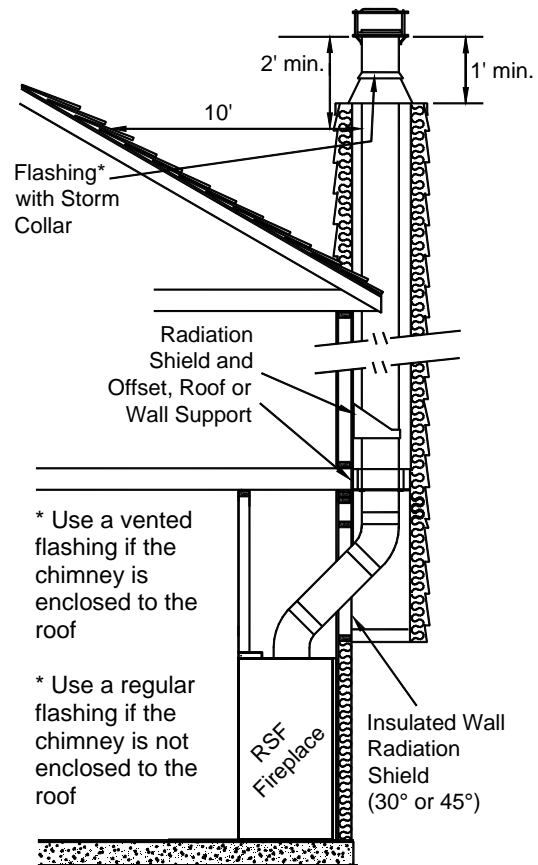

Figure 10 Offset Chimney Through a Wall Example

OFFSET CHIMNEY

An elbow may be installed directly on top of the fireplace if required. See the detailed offset charts in the EXCEL chimney installation manual. Use the offset option if you need to clear a joist or pass around a cupboard. See Figure 9 and Figure 10 for examples.

- Maximum offset angle:
 - In **USA**: 30°;
 - In **Canada**: 45°.
- Maximum number of elbows: four, resulting in two offsets and returns.

Install the fireplace and chimney as described earlier. When you require an elbow, proceed as follows:

1. Install the required elbow. Turn it in the desired direction, and fasten it to the other section with 3 metal screws at the joints.
2. Install enough lengths to obtain the desired offset. Secure each joint with 3 metal screws.
3. Use another elbow to return the chimney to the vertical direction.
4. Install a roof support, a wall support, or an offset support above each offset to support the weight of the chimney (elbows are not designed to support the chimney above an offset). The support can be installed anywhere practical along the vertical course of the chimney as long as it is above the offset.

Through the Wall Offset

You can also go through the wall at an angle starting directly at the fireplace as depicted in Figure 10. An angled wall insulated radiation shield (XM-8EWRSI30 or XM-8EWRSI45) must be used wherever the chimney passed through an exterior wall. Make sure you have enough ceiling height. If not, you might want to consider installing the fireplace in an outside chase.

If the chimney is enclosed once outside of the house, do not install the outside plate of the angled wall insulated radiation shield.

Refer to the angled wall insulated radiation shield installation sheets for more detailed installations instructions.

Make sure not to forget to install the small shield to protect the top area of the opening through the wall. This small shield is provided with the angled wall insulated radiation shield.

CHASE ENCLOSURE

If the chimney runs up the outside of the house, we recommend that it be enclosed in a chase structure. The chase should be constructed in such a way that it is an extension of the home. It should be well insulated between the footings and the floor of the home to prevent heat loss. If the climate in your area is mild, insulate the chase at least to the first firestop. If the climate in your area is very cold, insulate the chase to the top to keep the chimney warmer, increase the draft, and reduce creosote buildup. We also recommend insulating the ceiling of the chase just as if it were in the attic space. This will prevent cold air from dropping down through the chase and into the room where the fireplace is installed (see Figure 11).

Some local codes require that the walls be insulated, vapor sealed and sheathed with a fire rated gypsum board (see Figure 11). We strongly recommend this procedure for all installations to prevent cold drafts from

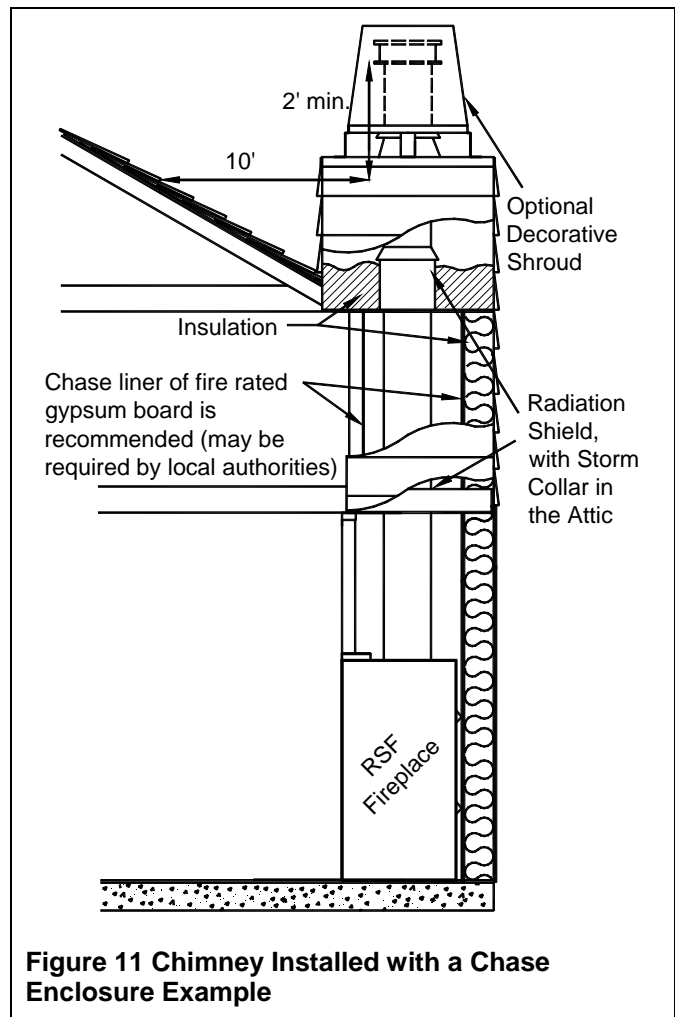

Figure 11 Chimney Installed with a Chase Enclosure Example

originating in the fireplace enclosure. If you follow this procedure, we recommend that you do not insulate the wall above the front of the fireplace.

♦ **REMEMBER:** Check local codes concerning installation requirements and restrictions in your area.

MASONRY CHIMNEY

Installing your DELTA FUSION fireplace with a masonry chimney still requires using EXCEL chimney from the top of the fireplace to the wall where it will connect to a listed liner that will run up inside the masonry chimney (see Figure 12).

The stainless steel liner should be fitted inside the clay liner all the way to the top of the masonry chimney. It is not meant to replace the clay liner. You can use either the EXCEL liner or any other listed liner to ULC-S635, ULC-S640 or UL-1777.

Special care is to be taken to make sure that you have a good solid connection between the EXCEL chimney and the liner. A masonry adaptor (FO-FDM8) was designed specifically for that purpose and is available from your RSF dealer. It will attach to the liner with 3 stainless steel rivets (provided) and to the EXCEL chimney with 3 screws (provided).

After mortaring in place, the connection between the EXCEL chimney and the liner should not be visible in order to isolate the heat released through the liner from the fireplace enclosure.

As depicted in Figure 12, you must install at least one 18" length of EXCEL chimney after the EXCEL chimney elbow. The uppermost part of the EXCEL chimney - where it enters the masonry chimney - must be a minimum of 12" from the ceiling.

♦ **NOTE:** If the ceiling is high enough, you can install one or more EXCEL chimney lengths directly on the fireplace before the elbow.

If you use a flexible liner, make sure to be careful when cleaning to ensure that the stainless steel flexible liner is not dislodged in any way.

Using an Existing Masonry Chimney

❖ **WARNING: IF YOU ARE CONSIDERING USING AN EXISTING CHIMNEY, IT MUST FIRST BE THOROUGHLY INSPECTED BY AN AUTHORITY HAVING JURISDICTION TO DETERMINE THE FOLLOWING:**

1. The masonry chimney is well constructed and fully lined, in accordance with Local Building Codes and the National Building Code of Canada (NBC) or National Fire Protection Association chimney standard (NFPA 211).
2. It has been thoroughly cleaned of any soot or creosote residue and inspected to determine that it is in good working condition.
3. There is no insulation of any type in contact with the masonry chimney and there is no insulation stuffed anywhere in the chimney.
4. All the necessary clearances around the masonry chimney, along the complete run of the chimney, are respected as per NBC or NFPA 211. If the masonry chimney is enclosed in drywall, openings will probably be required in order to verify clearances at all points.
5. The masonry chimney will only be used for the fireplace and no other appliance.

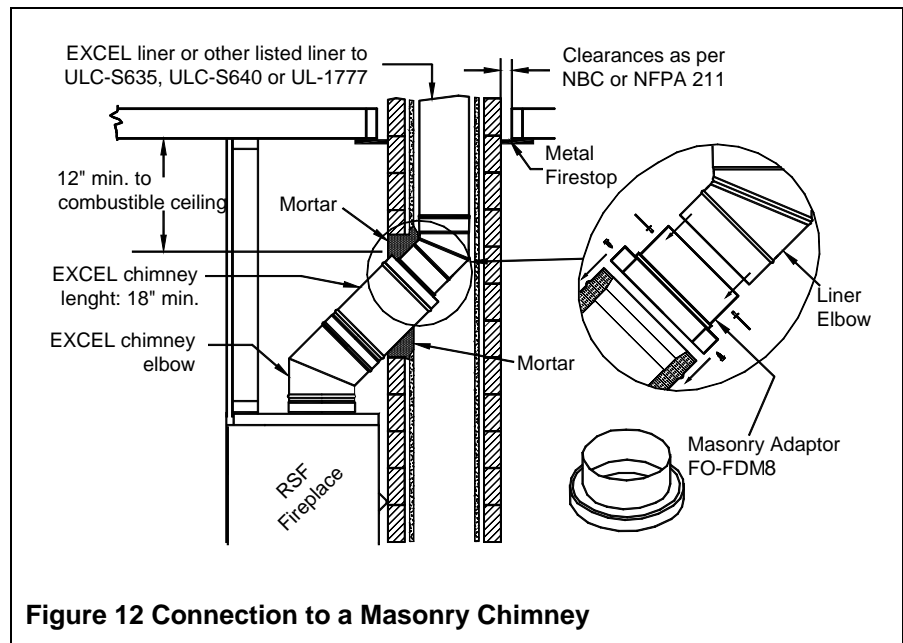

Figure 12 Connection to a Masonry Chimney

If major repairs are required to meet the above conditions, a new chimney should be constructed.

To make the hole through the masonry chimney and make the connection to the fireplace, we recommend that you follow these steps:

1. Sight-in and mark the outline of where the EXCEL chimney will penetrate the masonry chimney.
2. Using a large ($\frac{3}{4}$ " - 2") masonry drill bit, drill a hole exactly in the center of the oval outline. With a masonry hammer and drill, slowly enlarge the hole to the size required. Remember to work from the center out. Be especially careful with the clay liner behind the brick because three sides of it must stay in place.
3. Bring the stainless steel liner down from the top of the chimney.

If you are using a rigid liner you will need enough room to secure an elbow to it with at least two screws.

If it is difficult to install rigid stainless steel liner in the existing masonry chimney or for a masonry chimney with less than 10"x10" inside, a listed stainless steel flexible liner can be used along with a flexible/rigid adaptor (LM-8LAF) available from your RSF dealer.

4. Install the liner elbow and masonry adaptor on the lower end of the liner.
5. Move the fireplace forward enough to install the EXCEL chimney on the fireplace (elbow and length) then move the fireplace back into position as you connect the masonry adaptor to the EXCEL chimney.

Using a New Masonry chimney

Since the masonry chimney is not build yet, we recommend that you position your fireplace, install the EXCEL chimney on it and connect to the first length of liner before building the chimney as explained above and shown in Figure 12 . The liner sections can easily be installed as the layers of brick are being placed. Since this is a new chimney, we recommend that you build it to the right size so you do not have to ovalize the liner but if you choose to use a 6"x10" clay liner you will need to ovalize the stainless steel liner to fit into the clay liner.

◆ **REMEMBER:** The stainless steel liner should be fitted inside the clay liner all the way to the top of the masonry chimney. It is not meant to replace the clay liner.

FINISHING AROUND THE FIREPLACE

Finishing materials that cover the facing of the fireplace **MUST BE NON-COMBUSTIBLE** (e.g. brick, slate, ceramic tile, etc.). Drywall cannot get closer to the fireplace than the side standoffs and the top clearance specified in Table 1 (L) and shown in Figure 4.

❖ **WARNING: MAKE SURE TO RESPECT THE TOP CLEARANCE SPECIFIED IN TABLE 1 (L).**

HEARTH EXTENSION

The area immediately in front of the fireplace must be protected by a non-combustible material such as brick, tile, stone, or slate. Refer to Table 1 (G-H) for the depth and width the hearth protection should extend beyond the front and both sides of the door opening (see Figure 1). There is no minimum thickness required for the hearth extension.

BENEATH HEARTH EXTENSION

If the DELTA FUSION is installed on a non-combustible floor, the spark guard specified below is not required.

Install the spark guard provided (5" x 36" piece of sheet metal) halfway under the fireplace and halfway under the hearth extension and centered on the door opening. The spark guard will extend 2½" beneath the fireplace. This will make certain that sparks cannot lodge in this area and start a fire. If necessary, the provided spark guard can be cut to the minimum width specified in Table 1 (I).

If you are preparing a raised installation, you will need a custom made spark guard, either a "Z" shaped spark guard or a right angle spark guard (see Figure 13). The Z-shaped spark guard must be used if the height between

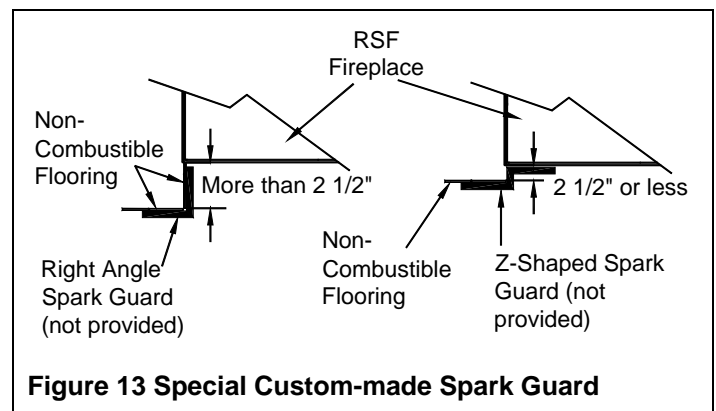

Figure 13 Special Custom-made Spark Guard

the bottom of the fireplace and the top of the non-combustible flooring of the hearth extension is less than or equal to 2 ½". The height of the Z-shaped spark guard must equal the distance between the floor and the base of the unit and go under the hearth extension and the fireplace by at least 2 ½". If the unit is installed higher than 2 ½" from the top of the flooring, a right angle spark guard is necessary. The sides of the right angle spark guard should be at least 2 ½" x 2 ½" and must be covered with non-combustible material. Any custom-made spark guard must have the minimum width specified in Table 1 (I), and be installed centered on the door opening.

◆ **NOTE:** Custom-made spark guards are not supplied.

MANTEL

Masonry and other non-combustible mantels (shelf and posts) can be placed anywhere on and around the fireplace facing, without blocking any of the bottom and top louvers.

For combustible mantel shelves, please see Table 1 (J-K) for the maximum depth and its installation clearance requirements. See Figure 1 for an example.

Vertical mantel posts on the sides of the fireplace opening must be non-combustible. Combustible mantel posts are not permitted unless they meet the clearance required to a perpendicular sidewall (see Table 1 (B)).

The only combustible material accepted below the minimum clearance for combustible materials above the fireplace (see Table 1 (L)) is for a mantel shelf.

REFRACTORY BRICK INSTALLATION

The refractory bricks for the DELTA FUSION fireplace are installed in the fireplace at the factory. If, for any reason they need to be replaced, the following order should be observed (see Figure 14). To remove any of the refractory bricks, just follow the installation procedure in the reverse sequence. Refer to Figure 14 to adequately identify which refractory brick is the right and which is the left at each step of the installation.

1. First, install both back refractory bricks (left (1) and right (2)), centered against each other.
2. Then install both sides' refractory bricks (left (3) and right (4)). There is a bracket to hold each brick in place at the top of the firebox. You will need to slide the bricks under their bracket.
3. Continue by installing the two small side ash steps (5). The rough face of these bricks should be against the facing of the fireplace.
4. Now place the central ash step (6) in place. Again the rough face of the brick goes against the facing.
5. Continue with the central bottom refractory brick (7) and slide it in place under the pilot.
6. Finish by placing both left and right bottom refractory bricks (left (8) and right (9)) on each side of the central bottom brick.

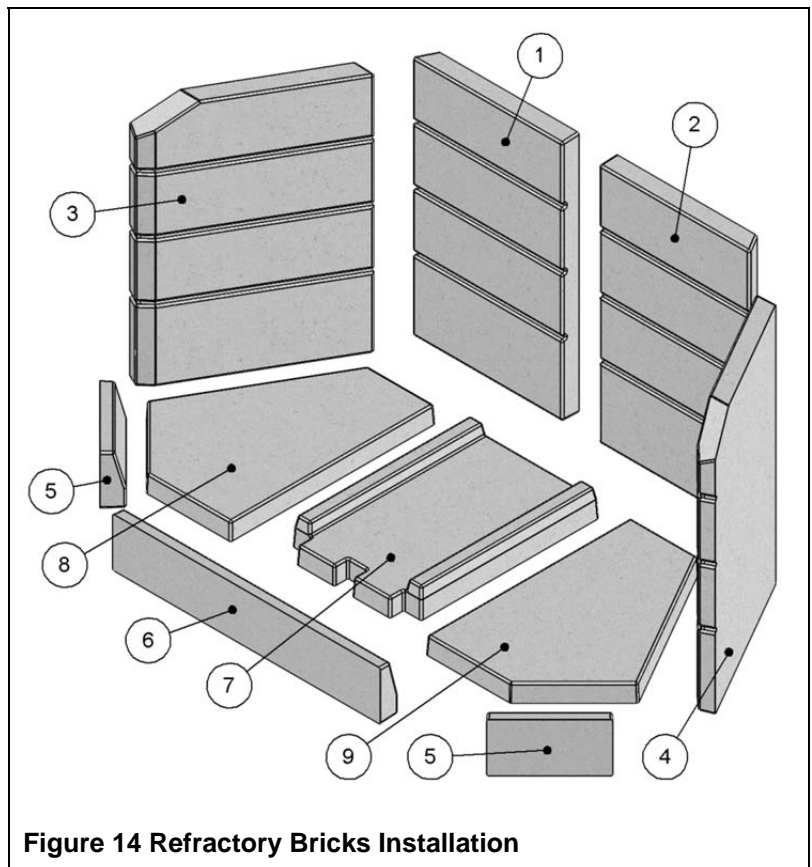

Figure 14 Refractory Bricks Installation

These refractory have been designed specifically for the DELTA FUSION and no modifications are required to ensure a proper fit.

LISTING LABEL

LISTED FACTORY FIREPLACE AND SPACE HEATER
MODEL: DELTA FUSION
 TESTED TO: UL-127 / ULC-S610 / ULC-S627
 EPA 2020 CERTIFIED AT 1.28 G/H

INSTALL AND USE ONLY IN ACCORDANCE WITH THE MANUFACTURER'S INSTALLATION AND OPERATING INSTRUCTIONS. **DO NOT OBSTRUCT COMBUSTION AIR INLET.** DO NOT USE A FIREPLACE INSERT OR OTHER PRODUCTS NOT SPECIFIED FOR USE IN THIS PRODUCT. OPERATE WITH DOOR FULLY OPEN OR FULLY CLOSED.

MINIMUM CLEARANCES TO COMBUSTIBLE MATERIALS	
SIDEWALL	24 1/2 IN. (622 MM) FROM FIREBOX OPENING
HEIGHT OF MANTLE SHELF: MAX. 12 IN. (305 MM) DEEP	24 IN. (610 MM) FROM FIREBOX OPENING
UNIT BACK, SIDES AND BOTTOM	0 IN. (0 MM) TO SPACERS

NO COMBUSTIBLE MATERIALS ON TOP OF FIREPLACE. SEE INSTALLATION MANUAL. COMBUSTIBLE MATERIALS ARE NOT PERMITTED ON FACE OF UNIT. NON-COMBUSTIBLE HEARTH EXTENSION MUST BE 18 IN. (457 MM) DEEP BY 36 IN. (914 MM) WIDE, AS SPECIFIED IN THE INSTALLATION MANUAL.

COMPONENTS REQUIRED FOR INSTALLATION:
 - USE 4 IN. OR 5 IN. (102 OR 130 MM) DIAMETER FLEXIBLE DUCT AND COMBUSTION AIR INLET ASSEMBLY.
 - USE THE ICC MODEL 8 IN. (203 MM) EXCEL CHIMNEY AND LISTED COMPONENTS AS PER INSTALLATION INSTRUCTIONS.

REFER TO MANUFACTURER'S INSTALLATION AND OPERATING INSTRUCTIONS FOR OPTIONAL COMPONENTS: FANS, GRAVITY VENT SYSTEM AND CENTRAL HEATING ACCESSORIES. ONLY ORIGINAL RSF OPTIONS SHOULD BE USED WITH THIS FIREPLACE, AND PURCHASED THROUGH RSF DEALERS.

WARNING: THIS FIREPLACE HAS NOT BEEN TESTED WITH AN UNVENTED GAS LOG SET. TO REDUCE RISK OF FIRE OR INJURY, DO NOT INSTALL AN UNVENTED GAS LOG SET INTO THE FIREPLACE.

REPLACE GLASS ONLY WITH 5MM CERAMIC GLASS. OPERATE ONLY WITH FIREBRICK IN PLACE. FOR USE WITH SOLID WOOD FUEL ONLY. DO NOT OVERFIRE UNIT.

THIS WOOD HEATER NEEDS PERIODIC INSPECTION AND REPAIR FOR PROPER OPERATION. CONSULT THE OWNER'S MANUAL FOR FURTHER INFORMATION. IT IS AGAINST FEDERAL REGULATIONS TO OPERATE THIS WOOD HEATER IN A MANNER INCONSISTENT WITH THE OPERATING INSTRUCTIONS IN THE OWNER'S MANUAL.

THIS SINGLE BURN RATE WOOD HEATER IS NOT APPROVED FOR USE WITH A FLUE DAMPER OTHER THAN AN OPEN-CLOSE FLUE DAMPER.

NE PAS ENLEVER CETTE ÉTIQUETTE
 CERTIFIÉ CONFORME PAR EPA (E.-U.) AUX NORMES 2020 D'ÉMISSION DE PARTICULES POUR LES APPAREILS À TAUX DE COMBUSTION UNIQUE EN UTILISANT UNE CHARGE NORMALISÉE.

INSTALLER ET UTILISER SELON LES INSTRUCTIONS D'INSTALLATION ET DE FONCTIONNEMENT DU MANUFACTURIER. **NE PAS OBSTRUER L'ENTRÉE D'AIR COMBUSTANT.** N'UTILISEZ PAS D'ENCASTRABLE OU AUTRES PRODUITS NON SPÉCIFIÉS POUR UTILISATION AVEC CE PRODUIT. FAIRE FONCTIONNER LE FOYER AVEC LA PORTE COMPLÈTEMENT OUVERTE OU FERMÉE.

DÉGAGEMENTS MINIMAUX AUX MATÉRIELUX COMBUSTIBLES	
MUR DE CÔTÉ	24 1/2 PO. (622 MM) DE L'OUVERTURE DE LA BOÎTE À FEU
HAUTEUR DE LA TABLETTE DE MANTEAU DE CHEMINÉE: MAX. 12 PO. (305 MM) DE PROFONDEUR	24 PO. (610 MM) DE L'OUVERTURE DE LA BOÎTE À FEU
ARRIÈRE, CÔTÉS ET BASE DE L'APPAREIL	0 PO. (0 MM) DES ESPACEURS

AUCUN MATÉRIEL COMBUSTIBLE SUR LE DESSUS DU FOYER.

LES MATÉRIELUX COMBUSTIBLES NE SONT PAS PERMIS SUR LA FACADE DE L'APPAREIL. LE PROLONGEMENT DE L'ÂTRE INCOMBUSTIBLE DOIT ÊTRE DE 18 PO. (457 MM) DE PROFONDEUR PAR 36 PO. (914 MM) DE LARGEUR MINIMUM SUIVANT LES SPÉCIFICATIONS DU MANUEL D'INSTALLATION.

PIÈCES REQUISES POUR L'INSTALLATION:
 - TUYAU FLEXIBLE DE 4 PO. OU 5 PO. (102 OU 130 MM) DE DIAMÈTRE ET PRISE D'ENTRÉE D'AIR.
 - UTILISER UNE CHEMINÉE EXCEL 8 PO. (203 MM) DE DIAMÈTRE DE ICC ET SES COMPOSANTS HOMOLOGUÉS SELON LES INSTRUCTIONS D'INSTALLATION.

VOIR LES INSTRUCTIONS D'INSTALLATION DU MANUFACTURIER POUR LES COMPOSANTS OPTIONNELS: VENTILATEURS, SYSTÈME D'ÉVENT PAR GRAVITÉ ET ACCESSOIRES DE CHAUFFAGE CENTRAL. SEULES LES OPTIONS ORIGINALES DE RSF DOIVENT ÊTRE UTILISÉES ET ACHETÉES PAR L'ENTREPRISE DE DÉTAILLANTS RSF.

AVERTISSEMENT: CE FOYER N'A PAS ÉTÉ TESTÉ AVEC UNE BÛCHE À GAZ SANS ÉVÈNT. POUR RÉDUIRE LES RISQUES DE FEU ET DE BLESSURES, NE PAS INSTALLER DE BÛCHE À GAZ SANS ÉVÈNT DANS CE FOYER.

LE REMPLACEMENT D'UNE VITRE DOIT SE FAIRE AVEC UNE VITRE CÉRAMIQUE DE 5 MM D'ÉPAISSEUR SEULEMENT. OPÉRER SEULEMENT AVEC LES PIERRES RÉFRACTAIRES EN PLACE. POUR UTILISATION AVEC DU BOIS SEULEMENT. NE PAS SURCHAUFFER L'APPAREIL.

CET APPAREIL AU BOIS DOIT ÊTRE INSPECTÉ PÉRIODIQUEMENT ET MAINTENU EN BON ÉTAT DE FONCTIONNEMENT. RÉFÉREZ-VOUS AU MANUEL DU PROPRIÉTAIRE POUR PLUS D'INFORMATION. IL EST INTERDIT PAR LES LOIS FÉDÉRALES D'OPÉRER CET APPAREIL AU BOIS SANS RESPECTER LES CONSIGNES D'OPÉRATION DU MANUEL DU PROPRIÉTAIRE.

CET APPAREIL AU BOIS N'EST PAS APPROUVÉ AVEC UN REGISTRE DE CHEMINÉE AUTRE QU'UN REGISTRE OUVERT-FERMÉ.



UL CERTIFIED
 SAFETY US+CA
 MH61405

NUMBER

SERIAL NO. / NO DE SÉRIE

DATE MANUFACTURED / DATE DE FABRICATION

MANUFACTURED BY / FABRIQUÉ PAR:

ICC, 400 J.F. KENNEDY,
 ST-JEROME, QC
 CANADA, J7Y 4B7



MADE IN CANADA / FABRIQUÉ AU CANADA

COMPLETE OPTIONS LIST

		Electricity required
FO-DUCT5	Insulated Duct 5 feet	
FO-FDHB5-N	Blower - Internal	✓
FO-FDHB6-1	Blower - Central Heat	✓
FO-FDHC6	Central Heat Control	✓
FO-FDHC6-1	Back Draft Damper	
FO-FDHCZ1	Zone Heat Control	✓
FO-FDHCZ2	Zone Damper Kit	✓
FO-FDM8	Masonry Chimney Adapter 8"	
FO-FDS45	45° Nailing Bracket	
FO-GRK10	Gasket Replacement Kit	
FO-KD3	Rock Retainer Kit	
FO-T	Central Heat Tee Option	
FO-V2	Gravity Vent Kit	
FO-VGC	Contemporary Grill for Gravity Vent	

REPLACEMENT PARTS

AVAILABLE SOON
Contact your RSF dealer



LIMITED WARRANTY

30 Years Limited Warranty

All RSF Woodburning Fireplaces models are warranted against defects in material and workmanship for a period of 30 years, subject to the following conditions:

During the first year **RSF Woodburning Fireplaces** will repair or replace, at our option, any parts which upon examination by an authorized **RSF Woodburning Fireplaces** representative, are found to be defective, except the parts listed in the EXCLUSIONS portion of this warranty. **RSF Woodburning Fireplaces** will also pay reasonable labor costs for the repair work.

During the second through fifth years **RSF Woodburning Fireplaces** will repair or replace, at our option, any parts which upon examination by an authorized **RSF Woodburning Fireplaces** representative, are found to be defective, except the parts listed in the EXCLUSIONS portion of this warranty. **RSF Woodburning Fireplaces** shall not be responsible for any labor costs associated with this repair work.

During the sixth through thirtieth years **RSF Woodburning Fireplaces** will provide replacement parts, if available, at 50% of the published retail price, except for the parts listed in the EXCLUSIONS portion of this warranty. **RSF Woodburning Fireplaces** shall not be responsible for any labor costs associated with this repair work.

EXCLUSIONS:

- Electrical components are warranted for one year only.
- Glass.
- Damage due to normal wear and tear, such as paint discoloration, worn gaskets, eroded or cracked refractory components.
- Repairs or replacements necessitated by vandalism, neglect, abuse, over-firing, improper fuel or fuel loads, or failure to adequately service the unit, as stated in the owner's manual.
- Repairs or replacements (particularly charges for travel and labor) not authorized by **RSF Woodburning Fireplaces** in advance.

LIMITATIONS:

- All items found to be defective will be replaced or repaired upon return of the defective part to an authorized **RSF Woodburning Fireplaces** dealer. **RSF Woodburning Fireplaces** will not be responsible for freight costs related to shipping replacement parts.
- Any complete fireplace, or part thereof, that is replaced or serviced under this warranty, will be warranted for a period not exceeding the remaining term of the original warranty.
- This warranty is not transferable.
- This warranty does not apply to damage to the appliance while in transit.
- This warranty does not apply if the installation does not conform to the installation requirements in the owner's manual.

RSF Woodburning Fireplaces is free of liability for any damages caused by the appliance, as well as material and labor charges incurred in the removal or re-installation of any **RSF Woodburning Fireplaces** fireplace under this warranty. Incidental or consequential damages are not covered by this warranty.

The remedies set forth herein are exclusive, and the liability of the seller shall not exceed the price of the fireplace or part thereof upon which the liability is based.

This warranty is expressly in lieu of all other warranties expressed or implied, including the warranties of merchantability and fitness for use and all other obligations or liabilities on the part of **RSF Woodburning Fireplaces**.